

Collar saddles with gaskets for rectangular ducts

SSCFBL



Description

Segmented collar saddles allow fabricating round branch ducts from square ventilation ducts. The installation requires cutting and opening in the duct being branched and fastening the piece with rivets or screws. The joint needs to be sealed with a silicone or acrylic compound. The saddle's form improves the air flow compared to standard ILSL collar saddles. This product is specifically recommended for branching systems that require air tightness class D according to EN 12237.

Available materials - Product code example

- SSCFBL-... - galvanized steel sheet
- SSCFBL-K-.. - 1.4301/304 stainless steel sheet
- SSCFBL-K-.. -316L - 1.4404/316L stainless steel sheet, molybdenum-enriched
- SSCFBL-A-... - AW-1050A H24 aluminium sheet
- SSCFBL-CU-... - M1E z4 copper sheet

Product code example

Product code: **SSCFBL - aaa**

type _____
 Ød₁ _____

Dimensions

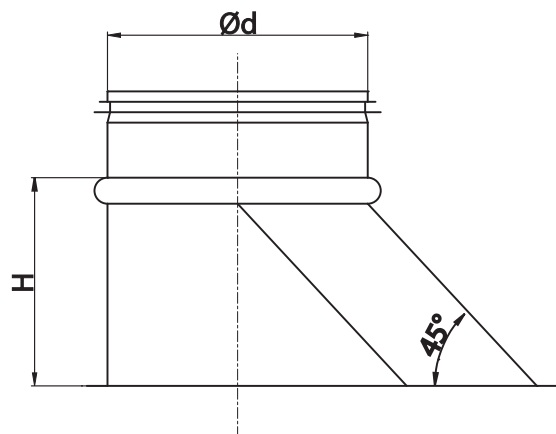

Ød [mm]	H [mm]
80	80
100	80
125	80
150	80
160	80
180	80
200	100
224	100
250	100
280	135
300	125
315	125
355	125
400	140
450	140
560	140
600	170
630	170