

Heat recovery ventilation unit with counterflow exchanger **HRU-PremAIR**



Description

Heat recovery ventilation unit HRU-PremAIR is a modern device with 350 / 450 or 500 m³/h air flow @ 100 Pa. The unit is made from cutting edge materials - PET or aluminum heat exchanger and EPP self-supporting casing. Depending on the model, following heat exchangers are used: counterflow heat exchanger made of PET, aluminum heat exchanger or counterflow, enthalpy exchanger.

Enthalpy exchangers in HRU-PremAIR-E series have a polymer membrane that effectively recovers heat and moisture from the extract air. Such membrane works like a membrane in waterproof trekking clothing i.e. it allows water vapour to pass through, but not liquid water and air. The enthalpy exchanger also blocks the transfer of odours, bacteria and spores.

The exchanger material, is needless to say, primarily optimized for maximum heat recovery efficiency.

The device operation is controlled by an advanced PCB with wireless communication between control panels and sensors. In addition, the HRU-PremAIR can be connected to the Internet and controlled by an mobile application.



HRU-PremAIR-450 is certified by Passive House Institute and can be used as a certified component in passive houses.

Available materials:

- HRU-PremAIR-350 - PET counterflow heat exchanger
- HRU-PremAIR-350E - counterflow enthalpy exchanger (heat and moisture recovery)
- HRU-PremAIR-450 - PET counterflow heat exchanger
- HRU-PremAIR-450E - counterflow enthalpy exchanger (heat and moisture recovery)
- HRU-PremAIR-500 - aluminium counterflow heat exchanger

Dimensions

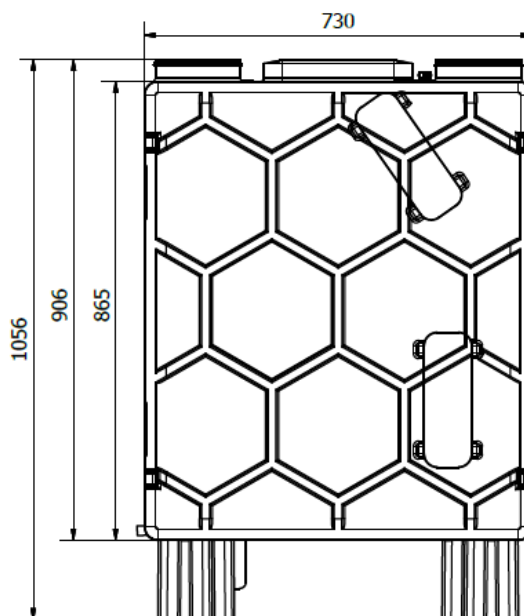
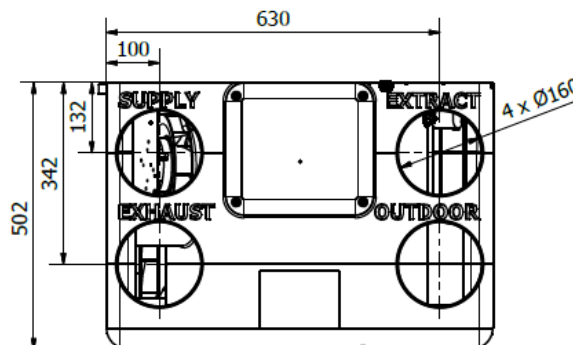

Heat recovery ventilation unit with counterflow exchanger

HRU-PremAIR

Performance

Key performance features:

- Heat recovery:
 - HRU-PremAIR-350 - up to 92,9%
 - HRU-PremAIR-350E - up to 91,2%
 - HRU-PremAIR-450 - up to 93,4%
 - HRU-PremAIR-450E - up to 91,2%
 - HRU-PremAIR-500 - up to 82,6%
- Certified heat exchanger from PET with high performance (Eurovent Certification) and hygienic compliance with DIN EN ISO 846 standard
- Enthalpy exchangers with antimicrobial properties of the membrane, resistant against mold and bacteria
- Hi-tech modern casing made of Expanded Polypropylene - EPP
- High mechanical resistance
- High thermal and acoustic insulation
- Modulated by-pass
- Free-cooling functions – also referred as Passive Cooling (no energy is needed) or Night Cooling (mostly happens during night), can be used to cool a building with outdoor air, when the room temperature is higher than the outside temperature
- Free-heating functions - also referred as Passive Heating (no energy is needed), can be used to heat a building with outdoor air, when the room temperature is lower than the outside temperature
- Performance tested according to EN 13141-7 standard
- Complies with ErP2018
- Wall mounting racks and feet included
- Replaceable duct connections
- Wireless control through mobile application or web browser
- Remote control possible by any CO₂ or RH wireless sensor
- Light weight construction – only 32 kg!
- POLISH product

Design

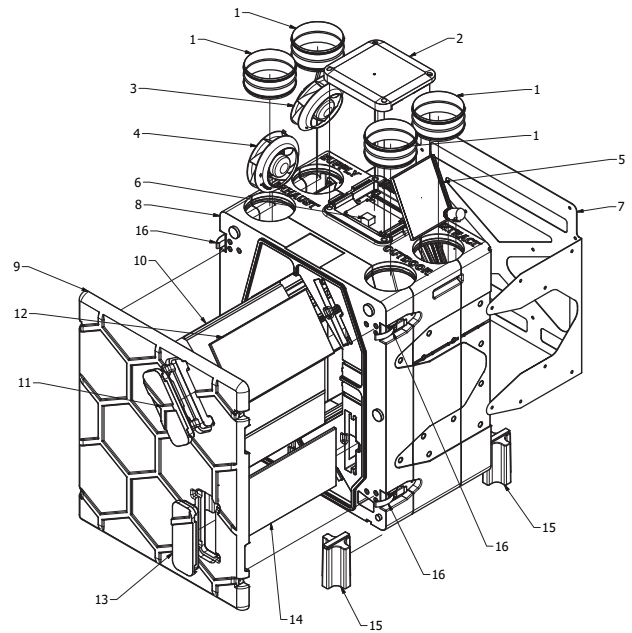

1. NSL connector (4pcs.)	9. Front cover
2. Control circuit cover	10. Heat exchanger
3. Supply fan	11. Extract filter cover
4. Extract fan	12. Extract filter G4
5. Bypass damper	13. Supply filter cover
6. Control circuit	14. Supply filter G4
7. Handling chassis	15. Mounting foot (4pcs.)
8. HRU housing	16. Clamp (4pcs.)

Heat recovery ventilation unit with counterflow exchanger

HRU-PremAIR

Technical data

	HRU-PremAIR-350	HRU-PremAIR-350E	HRU-PremAIR-450	HRU-PremAIR-450E	HRU-PremAIR-500
Efficiency % (acc.1253/2014)	90,7	84,7	88,0	82,1	81,5
Heat exchanger	counterflow, PET	counterflow, enthalpy	counterflow, PET	counterflow, enthalpy	counterflow, aluminium
Air flow (m ³ /h)	350 @ 100 Pa	350 @ 100 Pa	450 @ 100 Pa	450 @ 100 Pa	500 @ 100 Pa
Voltage (V/Hz)	230 / 50	230 / 50	230 / 50	230 / 50	230 / 50
Maximum power consumption (W)	180	180	270	270	315
Sound power level L _{WA} (dB (A))	56	56	59	59	61
Weight (kg)	32	32	32	32	32
Filters	Class G4 filter as per EN 779 (F7 optional)	Class G4 filter as per EN 779 (F7 optional)	Class G4 filter as per EN 779 (F7 optional)	Class G4 filter as per EN 779 (F7 optional)	Class G4 filter as per EN 779 (F7 optional)

Performance curve HRU-PremAIR-350

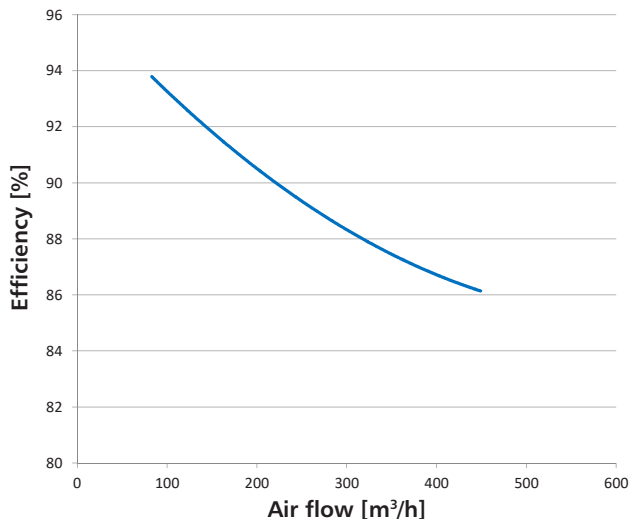

Performance curve HRU-PremAIR-450

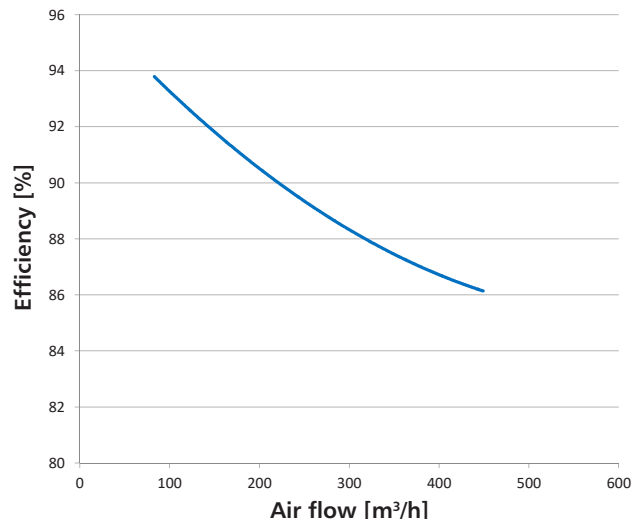

Performance curve HRU-PremAIR-500

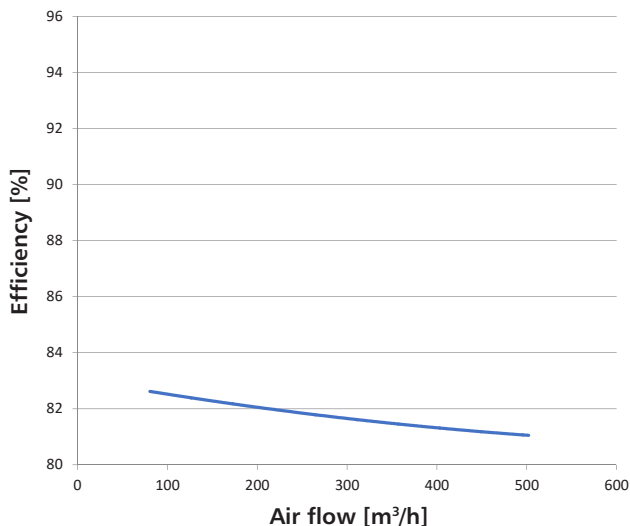

Performance curve - Heat (—) and moisture(—) recovery HRU-PremAIR-350E / HRU-PremAIR-450E

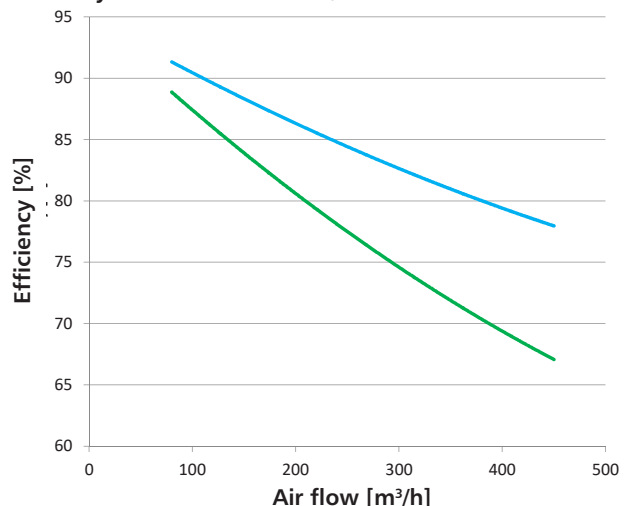

Heat recovery ventilation unit with counterflow exchanger

HRU-PremAIR

Air flow HRU-PremAir-350 / HRU-PremAir-350E

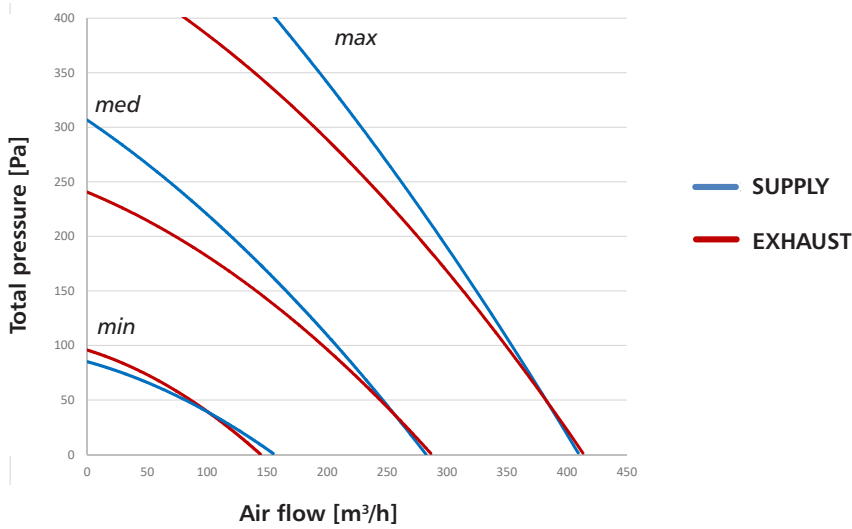

Air flow HRU-PremAir-450 / HRU-PremAir-450E

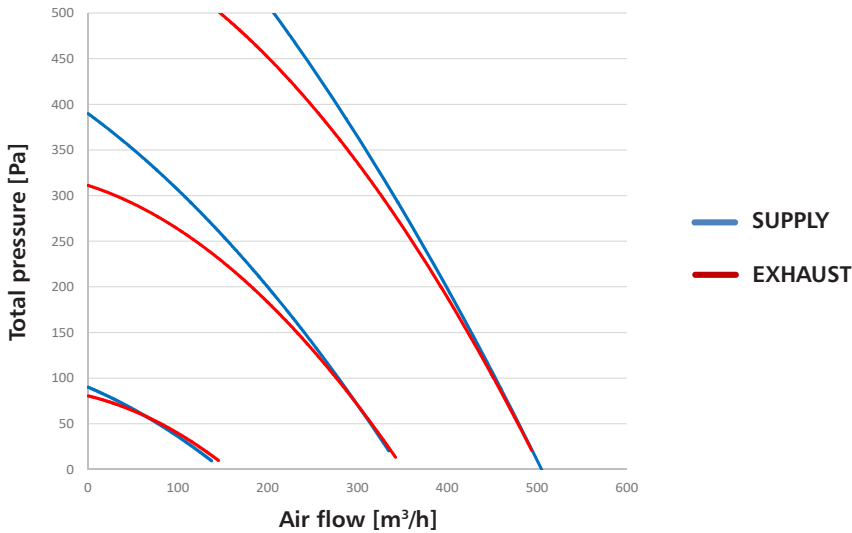

Air flow HRU-PremAir-500

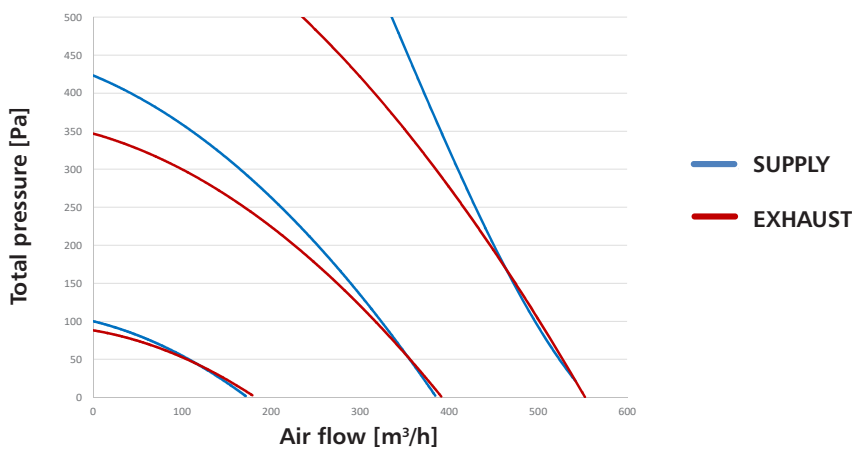

Heat recovery ventilation unit with counterflow exchanger **HRU-PremAIR**

Accessories

Filter HRQ-PremAIR-FILT-G4 (standard)

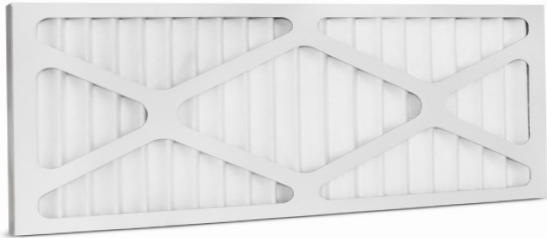

G4 pleated panel filters creates a larger media surface area for air filtration and ensures lower pressure drops. Filters are classified as in the ISO Coarse 70% according to ISO 16890 standards.

Code	Filter class	Dimensionsr [mm]
HRQ-PremAIR-FILT-G4	G4	423x223x23

Filter HRQ-PremAIR-FILT-F7 (optional)

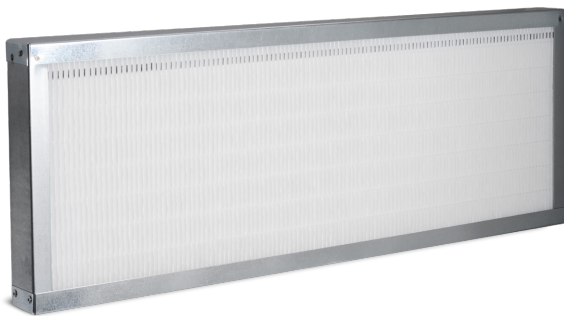

F7 is classified as a fine filter according to EN 779:2012 norm and as ePM₁ 55% in accordance with new standard ISO 16890.

Code	Filter class	Dimensions [mm]
HRQ-PremAir-FILT-F7	F7	423x223x25

Controller HRQ-PremAIR-BUT-LM11 (standard)



Standard (included) wireless 4-button controller allows to choose from 4 operating modes: Away, Home, Timer, Party. Range: 30 m (inside dwelling, 100 m in open space, additional antenna available).

Code	Power supply	Dimensions [mm]
HRQ-PremAIR-BUT-LM11	Battery CR2032	84x84x15

Controller HRQ-PremAIR-BUT-LM04 (optional)



Optional wireless 4-button controller allows to choose from 4 operating modes: Away, Home, Timer, Auto. Range: 30 m (inside dwelling, 100 m in open space, additional antenna available).

Code	Power supply	Dimensions [mm]
HRQ-PremAIR-BUT-LM04	Battery CR2032	84x84x15

Heat recovery ventilation unit with counterflow exchanger

HRU-PremAIR

HRQ-PremAIR-SENS-CO2 (optional)



Wireless, wall mounted CO2 sensor measures the dioxide level in the room (PPM). Sensor works as a unit controller and indicates the current status by means of a multicolour LED. Up to 20 wireless devices can be connected to a single ventilation unit.

Range: 30 m (inside dwelling, 100 m in open space, additional antenna available).

Code	Power supply	Dimensions [mm]
HRQ-PremAIR-SENS-CO2	230V	100x100x25

HRQ-PremAIR-SENS-RH (optional)



Wireless relative humidity sensor, wall mounted. Sensor works as a unit controller and indicates the current operation mode by means of a multicolour LED. Up to 20 wireless devices can be connected to a single ventilation unit.

Range: 30 m (inside dwelling, 100 m in open space, additional antenna available).

Code	Power supply	Dimensions [mm]
HRQ-PremAIR-SENS-RH	2x AA	100x100x25

HRQ-PremAIR-SENS-GATE (optional)



Internet gate allows to connect the PremAIR unit to Internet and control it through a mobile application.

Code	Power supply	Dimensions [mm]
HRQ-PremAIR-GATE	230V	80x105x20

Heat recovery ventilation unit with counterflow exchanger **HRU-PremAIR**

Mobile application HRU-PremAIR

Mobile application for controlling a home ventilation unit HRU-PremAIR-450 by ALNOR.

It allows to monitor and control the unit via local network and Internet as well:

- Mode selection (Away, Home, Party, Boost, Auto and Standby)
- Temperature readouts
- Fans efficiencies
- Defrost mode
- By-pass mode
- Filters conditions

Available for download in Google Play and App Store: PremAIR



Screen shot:



Heat recovery ventilation unit with counterflow exchanger

HRU-PremAIR**Energy class**

Model	Sound level L_{WA} dB(A)* [dB]	Air flow rate [m ³ /h]	Energy class			
			Manual control	Clock control	Central demand control (1 sensor)	Local demand control (2 sensor)
HRU-PremAIR-350	56	350	A	A	A	A
HRU-PremAIR-350E	56	350	A	A	A	A
HRU-PremAIR-450	59	450	A	A	A	A
HRU-PremAIR-450E	59	450	B	B	A	A
HRU-PremAIR-500	61	500	A	A	A	A

