

Plenum boxes with long connection spigot for air valve

FLX-PLO-EPP-L



The FLX-PLO-EPP-L plenum boxes are part of the FLX-REKU air distribution system designed for domestic mechanical ventilation systems, so-called the MVHR system, to which an air valve and FLX-HDPE / FLX-HDPE-A ducts with a diameter of Ø75 are mounted.

L version allows to install the valve through a concrete ceiling or a thick wall.

The FLX-PLO-EPP-L plenum boxes are made of expanded polypropylene, i.e. EPP, while Ø75 spigots are made of ABS.

Key features:

- EPP is an insulation material $\lambda=0.0038$, the wall thickness is about 8 to 31 mm.
- "Double" FLX-HDPE duct fixing - the male connection spigot with a gasket on the inside and EPP casing on the outside.
- The plenum boxes do not corrode.
- Long connection spigot ($\varnothing d_1$) for the air valve has 260 or 305 mm.
- 2 installation methods - with screws and wall plugs or with 17-25 mm-wide PB perforated tape.

The FLX-PLO-EPP-L plenum boxes are equipped with TPE gasket on $\varnothing d_2$ spigots as a standard - such connection with FLX-HDPE ducts is airtight and easy to make. For building residential ventilation systems in ATC2 (D) air-tightness class acc. to EN 17192:2018

Example of designation

Product code **FLX-PLO-EPP - L30 - 75 - 2 - 125 - F**

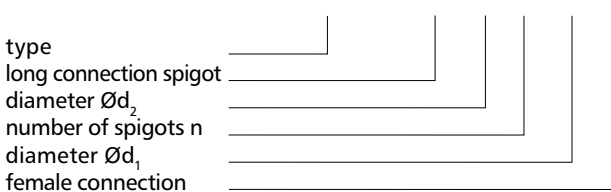

Dimensions

FLX-PLO-EPP-L26-75-2-125-F / FLX-PLO-EPP-L30-75-2-125-F

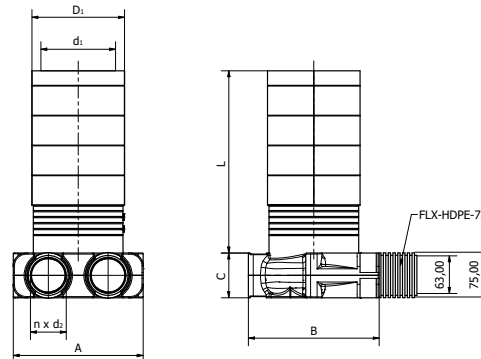

FLX-PLO-EPP-L30-75-3-125-F / FLX-PLO-EPP-L30-75-3-160-F

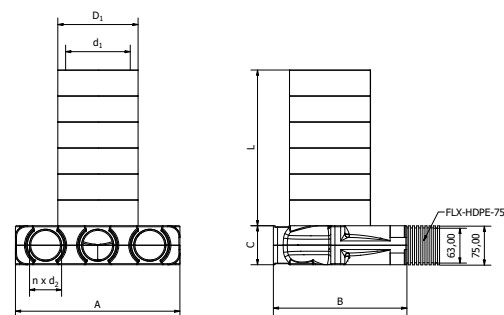

FLX-PLO-EPP-L22-75-4-...-F / FLX-PLO-EPP-L30-75-4-...-F

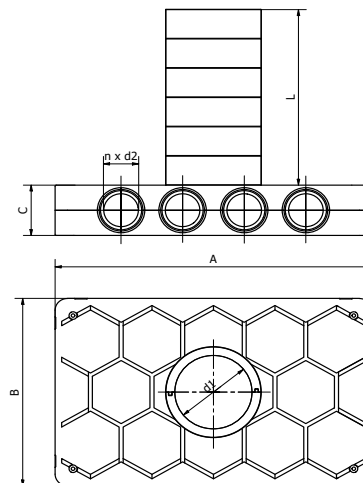

Product code A B C L D₁ d₁ n d₂

FLX-PLO-EPP-L26-75-2-125-F	217,5	194	75	260	155	125	2	63
FLX-PLO-EPP-L30-75-2-125-F	217,5	194	75	305	155	125	2	63
FLX-PLO-EPP-L30-75-3-125-F	315,5	256	75	300	155	125	3	63
FLX-PLO-EPP-L30-75-3-160-F	315,5	256	75	300	190	160	3	63
FLX-PLO-EPP-L22-75-4-...-F	514	320	86	225	155	125	4	63
					230	200		
FLX-PLO-EPP-L30-75-4-...-F	514	320	86	300	155	125	4	63
					230	200		

Plenum boxes with long connection spigot for air valve

FLX-PLO-EPP-L

Technical data

Pressure drop diagram for the supply plenum box: Ø100, Ø125

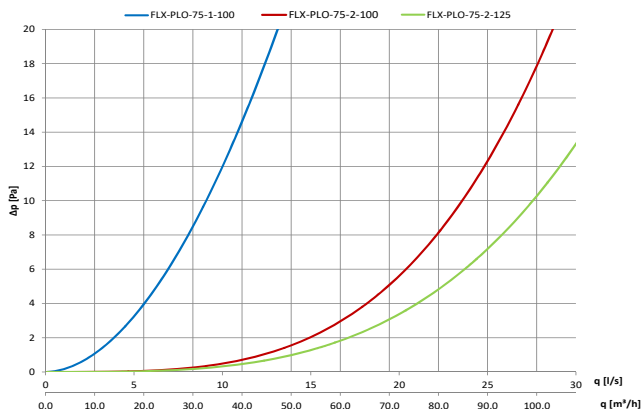

Pressure drop diagram for an exhaust plenum box: Ø100, Ø125

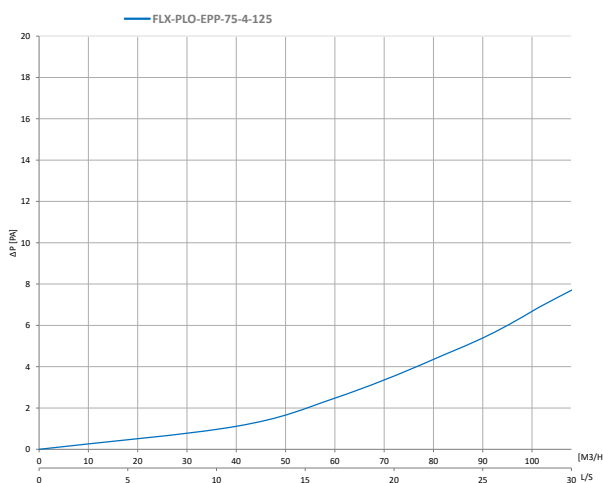
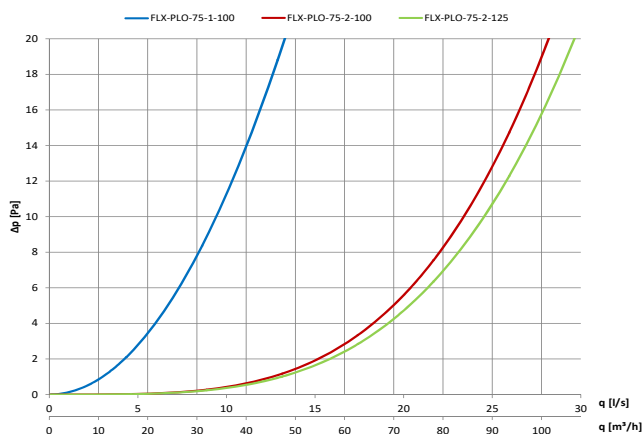

Service temperature	-25°C do +80°C	PN-EN 17192:2019
Reaction to fire	E	EN 13501-1
Thermal conductivity	$\lambda = 0,0038 \text{ W/(m}\cdot\text{k)}$	PN-EN 12664:2002
Microbial resistance	1a	Metoda A PN-EN ISO 846:2019

Performance versions:

FLX-PLO-EPP-L26-75-2-125-F



FLX-PLO-EPP-L30-75-3-160-F



FLX-PLO-EPP-L30-75-4-...-F

